

# ORDERING GUIDE - AFTERMARKET

USA

SAF-HOLLAND, Inc.

800.876.3929

CANADA

SAF-HOLLAND, Canada Ltd.

519-537-2366



## CBX40, CBX46 AND CBX50 Tandem Slide Suspension with Drum or Disc Brake Axle and CBX69 Tridem Slide Suspensions with Drum or Disc Brake Axle

### Ordering Guide Information: **PLEASE DOWNLOAD THIS FORM BEFORE COMPLETING.**

This form is designed to collect all necessary information about the suspension application requirements to help determine the appropriate CBX40, CBX46, CBX50 or CBX69 Series configuration for the trailer build.

For application and selection information, please reference our [Trailer Air Suspension Application Guide \(XL-AS11415SG-en-US\)](#).

If you have any questions regarding this document, please feel free to contact SAF-HOLLAND Customer Service at 1.800-876-3929

- Please complete all of the information requested on this ordering guide by filling in all appropriate fields.
- After submitting, print a copy of this ordering guide for your records, by clicking the "PRINT FORM" button.
- To clear the form, click the "CLEAR FORM" button.

### How-To Submit This Ordering Guide:

Submit completed ordering guide by clicking the "EMAIL" button next one of our SAF-HOLLAND ordering specialist.

### SUBMIT FORM TO:

#### USA

Debbie Doremire

#### CANADA

Jim Visser

Matt Tubbe

## GENERAL INFORMATION

### CUSTOMER INFORMATION

Date:

Estimated Trailers for this Specification:

Company Name:

Contact Name:

Street Address:

City:

State/Province:

Zip Code/Postal Code:

Telephone:

Fax:

E-Mail:

### END USER INFORMATION

Company Name:

Contact Name:

Street Address:

City:

State/Province:

Zip Code/Postal Code:

Telephone:

Fax:

E-Mail:

## DRUM BRAKE AXLE CONFIGURATION (Complete Drum or Disc Brake Section as Required)

### FIXED PORTION OF CONFIGURATION

Drum Brake

Brake Shoe/Lining: SAF Standard Extended Life Linings

Axle Rating: 20,000 - CBX40 (2 axles)

23,000 - CBX46 (2 axles), CBX69 (3 axles)

25,000 - CBX50 (2 axles)

Tire Inflation System: 3-Hole, Drilled and Tapped with Freeze Plugs

S-Cam: 28 Spline Standard, Medium Length (Long Length for Yoke mount only)

### OPTIONAL PORTION OF CONFIGURATION

Spindle: Tapered Parallel

Dual/Wide Base Single: Dual Wide Base Single\*

\*Note: 2" offset not approved for tapered axles.  
(See XL-AA20005WI-en-US for axle derating.)

Brake Size: 16.5" x 7" 16.5" x 8-5/8"

Axle Track/Frame Width/Beam Centers: 71.5"/42"/36" 77.5"/48"/42"

### OPTIONS SOLD SEPARATELY

Cam Enclosures: Order Part No. 51830030, Quantity 2 (CBX40/46/50)  
(Cam Enclosure Retrofit Kit - Medium Cam) Quantity 4 (CBX69)

# ORDERING GUIDE - AFTERMARKET



## CBX40, CBX46 AND CBX50 Tandem Slide Suspension with Drum or Disc Brake Axle and CBX69 Tridem Slide Suspensions with Drum or Disc Brake Axle

### DRUM BRAKE WHEEL END CONFIGURATION

Wheel Ends Required:    Yes    No    If no, skip section and continue to Slider/Suspension Configuration.

#### FIXED PORTION OF CONFIGURATION

Hub Material: Ductile Iron

Autom. Slack Adjuster: Standard 5.5"

Spindle Nut: ZipTorq®

Drum Material: Cast

Bearing: Standard

Wheel Fasteners: 2 Ship Nuts

Hubcap Type: Standard Bolt-On

Brake Chamber: Standard 30/30, 2.5" Stroke

Hub Style: Hub Piloted

Seal: Standard Spindle Mount

Stud Length: Long

#### OPTIONAL PORTION OF CONFIGURATION

Lube Type:    SAE 80/90 Oil    Semi-Fluid Grease

#### OPTIONS SOLD SEPARATELY

ABS Sensor (400 mm Lead Length):    Yes    No  
 Order Part No. 102230000020  
 Specify Quantity Needed:    2    4    6

Wheel Fasteners: (Flange Nut, M22 x 1.5)

Order Part No. 04247301201    (20 Needed Per Axle)  
 (Specify Quantity Required)

Dust Shields:    Order Part No. 03005023500Z, Quantity 4 (CBX40/46/50)  
 (Dust Shield Kit)    Quantity 6 (CBX69)

### DISC BRAKE AXLE CONFIGURATION - & (Complete Disc Brake or Drum Brake Section as Required)

#### FIXED PORTION OF CONFIGURATION

Disc Brake - 22.5"

Axle Rating: 20,000 - CBX40 (2 axles)

23,000 - CBX46 (2 axles), CBX69 (3 axles)

25,000 - CBX50 (2 axles)

Tire Inflation System: 3-Hole, Drilled and Tapped with Freeze Plugs

ABS Sensor: (400 mm Lead Length) Installed on all axles.

Note: All disc brake axles come with wheel end components.

#### OPTIONAL PORTION OF CONFIGURATION

New P89 - 5 Year Warranty

Options: Spindle:    Tapered    Parallel

Lube Type:    SAE 80/90 Oil    Semi-Fluid Grease

P89 Plus - 7 Year Warranty \*Only available with SAF compact bearing and parallel spindle.

Dual/Wide Base Single:    Dual    Wide Base Single

Axle Track/Frame Width/Beam Centers:    71.5"/42"/36"    77.5"/48"/42"\*

#### OPTIONS SOLD SEPARATELY

Wheel Fasteners: (Flange Nut, M22 x 1.5)

Order Part No. 04247301201    (20 Needed Per Axle)  
 (Specify Quantity Required)

Dust Shields:    Order Part No. 102230000040, Quantity 4 (CBX40/46/50)  
 (Dust Shield Kit)    Quantity 6 (CBX69)

# ORDERING GUIDE - AFTERMARKET

## CBX40, CBX46 AND CBX50 Tandem Slide Suspension with Drum or Disc Brake Axle and CBX69 Tridem Slide Suspensions with Drum or Disc Brake Axle

### SLIDER/SUSPENSION CONFIGURATION

#### FIXED PORTION OF CONFIGURATION

Slider Pin Extractor: Air Release

PosiLok™: Walk/Drop Solutions

Air Control Kit: HCV with Integral Dump 3/8" Low Flow

#### OPTIONAL PORTION OF CONFIGURATION

Slider Model: CBX40 (Tandem)    CBX 46 (Tandem)  
CBX50 (Tandem)    CBX69 (Tridem)

Ride Height: 16"    16.5"    17"

Frame Width: See Axle Portion of Configuration

Body Rail Style: 1.375" x 6" (Binkley Style) Outside Shim  
1.375" x 6" (Binkley Style) Inside Shim  
1.625" x 4" (Hutch™ Style) Outside Shim

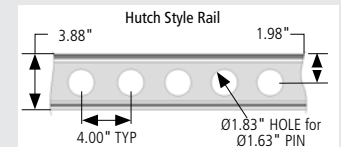
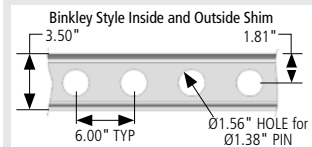

CBX69 Axle Spread: 60"    72"  
CBX40, CBX46, CBX50 Axle Spread: 49"

### BRACKET CONFIGURATION

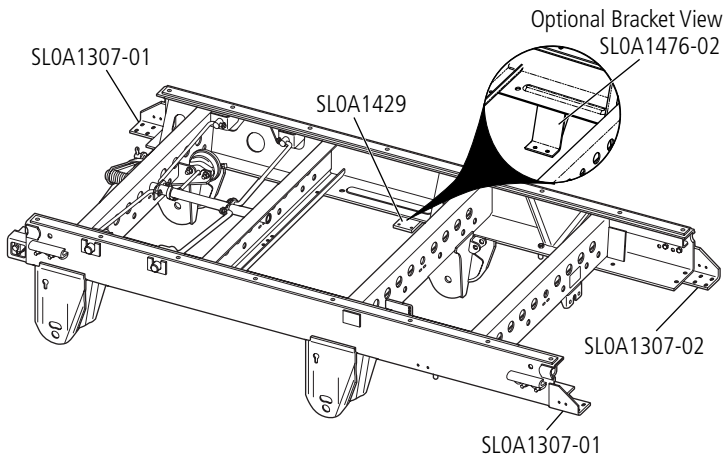

#### OPTIONS SOLD SEPARATELY

Shock Straps:	Yes	No	
	Order Part No. 90549928 (For 16" Ride Height)		Quantity 4 (CBX40/46)
	Order Part No. 90549920 (For 16.5" and 17" Ride Height)		Quantity 4 (CBX40/46)
	Order Part No. 90549937 (For 16", 16.5" and 17" Ride Height)		Quantity 4 (CBX50) Quantity 6 (CBX69)
Mud Flap Brackets:	Order Part No. SLOA1307-01, Quantity 1 and SLOA1307-02, Quantity 1		
Stinger Bracket:	Order Part No. SLOA1307-01, Quantity 1		
Air Tank Brackets:	Order Part No. SLOA1429, Quantity 2		
Optional 6.25" Drop Brackets:	Order Part No. SLOA1476-02, Quantity 2		

# ORDERING GUIDE - AFTERMARKET

## CBX40, CBX46 AND CBX50 Tandem Slide Suspension with Drum or Disc Brake Axle and CBX69 Tridem Slide Suspensions with Drum or Disc Brake Axle

### DIMENSIONAL VIEWS

#### CBX40, CBX46 AND CBX50 WITH DRUM BRAKE AXLES SHOWN All Dimensions Are Reference

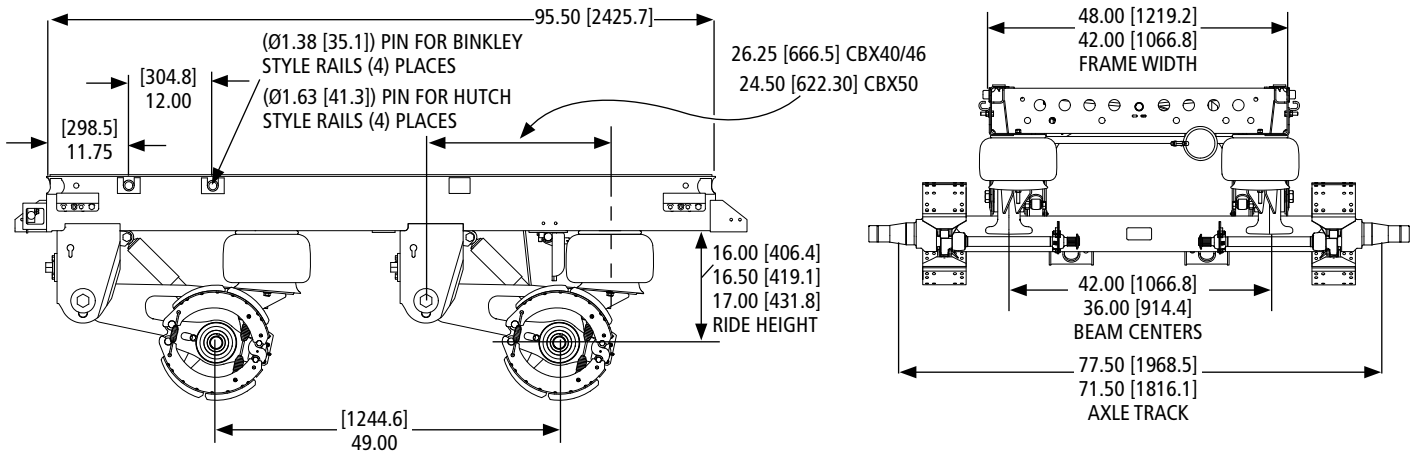

#### CBX69 WITH OR DISC BRAKE AXLE SHOWN All Dimensions Are Reference

