

DockMaster 400e (DM400e)

Installation Instructions
Maintenance Instrucions
Service Parts

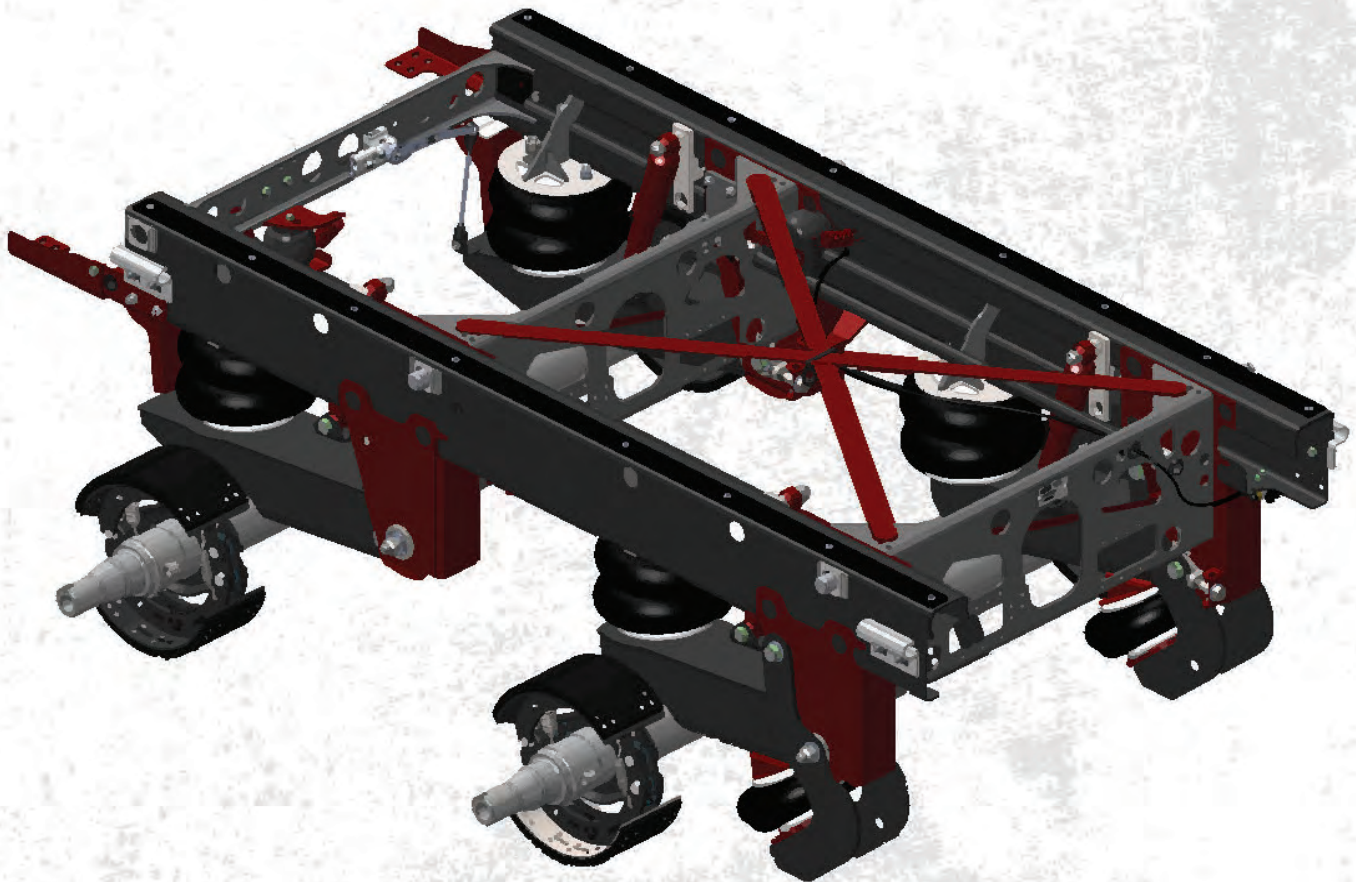

Document #: D714249
Revision: B
Revision Date: 07/2018

Reyco Granning Suspensions
1205 Industrial Park Drive
Mount Vernon, MO 65712
Phone: 417-466-2178
Fax: 417-466-3964
ISO Certified: 9001:2015
www.reycogranning.com

COMPANY PROFILE

Reyco Granning Suspensions was formed by the merger and acquisition of two well-known names in the heavy-duty vehicle suspension industry: Reyco and Granning.

Reyco grew out of the Reynolds Mfg. Co. and was first known as a major supplier of brake drums for heavy-duty vehicles, and later developed a full line of air and steel spring suspensions for trucks, busses, trailers, and motorhomes.

Granning Air Suspensions was founded in 1949 in Detroit, Michigan as a manufacturer of auxiliary lift axle suspensions. Granning later became an innovator of independent front air suspensions for the motorhome industry.

Reyco Granning LLC was formed in early 2011 through a partnering of senior managers and MAT Capital, a private investment group headquartered in Long Grove, Illinois.

Reyco Granning manufacturing facilities are certified to the ISO9001:2015 standards, a globally recognized assurance that quality standards have been established and are maintained by regular rigorous audits.

- SAFETY PROCEDURES & INFORMATION |-----○ i.1
 - SAFETY FIRST |-----○ i.1
 - OPERATOR SAFETY |-----○ i.1
 - Lifting |-----○ i.1
 - Parts Handling |-----○ i.1
 - Welding |-----○ i.1
 - Torque |-----○ i.1
 - SUSPENSION SAFETY |-----○ i.2
 - Overloading The Suspension |-----○ i.2
 - Air Springs |-----○ i.2
- SLIDER BODY RAIL INSTALLATION |-----○ i.3
- LOADBLOCK INSTALLATION & PLUMBING |-----○ i.4
 - Loadblock Installation |-----○ i.4
 - Loadblock Plumbing |-----○ i.4
- PLUMBING |-----○ i.5
 - Height Control Valve |-----○ i.5
 - Ride Height Measurement & Adjustment |-----○ i.6
 - Air Pin Release |-----○ i.7
- ALIGNMENT PROCEDURE |-----○ i.8

Installation Instructions Model DM400e

SAFETY FIRST

Be sure to read and follow all installation and maintenance procedures.

LIFTING

Practice safe lifting procedures. Consider size, shape and weight of assemblies. Obtain help or the assistance of a crane when lifting heavy assemblies. Make sure the path of travel is clear.

PARTS HANDLING

When handling parts, wear appropriate gloves, eyeglasses and other safety equipment to prevent serious injury.

WELDING

When welding, be sure to wear all personal protective equipment for face and eyes, and have adequate ventilation. When welding, protect spring beams and air springs from weld spatter and grinder sparks. Do not attach "ground" connection to springs.

Under normal use, steel presents few health hazards. Prolonged or repeated breathing of iron oxide fumes produced during welding may cause siderosis.

TORQUE

Proper tightening of the nuts and alignment bolts are high priority items. A fastener system is considered "loose" any time the torque is found below required values. Failure to maintain the specified torque and to replace worn parts can cause component failure resulting in accident with consequent injury.

NOTE: It is extremely important after the first 1,000 - 3,000 loaded miles (1,600 - 4,800 kms) of operation, and with each annual inspection thereafter, that all of the bolt and nut tightening recommendations be followed. Any loose fasteners must be retorqued to comply with warranty requirements and to ensure long, trouble-free performance.



Welding Helmet

Welding Apron

Welding Gloves

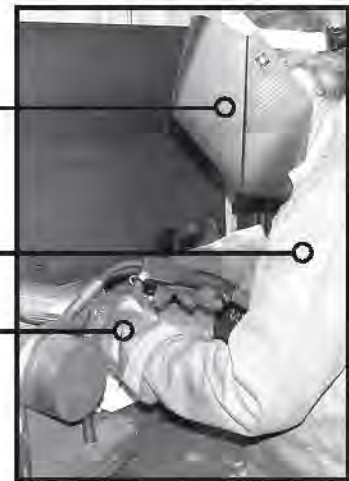

Torque Wrench

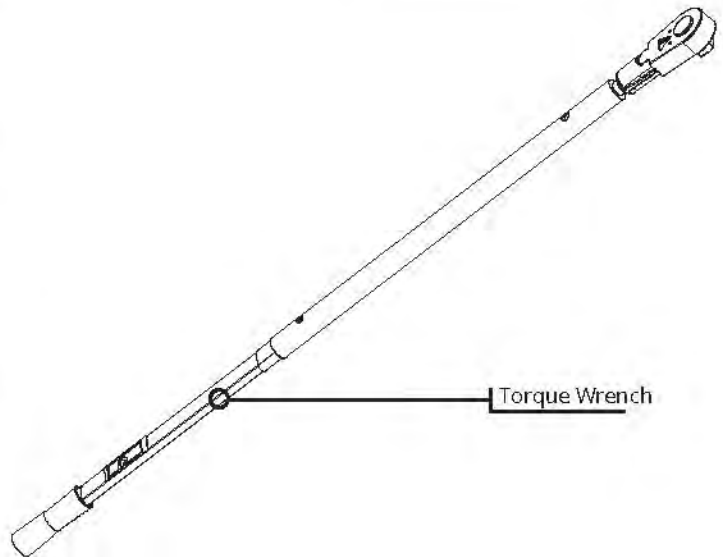



OVER LOADING

Overloading is the practice of transporting cargos that surpass the specified vehicle's ratings. Overloading can cause component failure, resulting in accidents and injuries.



This symbol indicates to the reader to use caution when seen and to follow specific requirements or warnings stated.



CAUTION: Specific torque requirements are recommended.

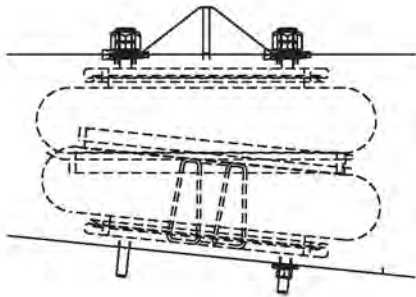

AIR SPRINGS

The air springs are equipped with internal bump stops for safety. However, do not operate the loaded unit on the bump stops for any extended periods of time, except to move the unit to a repair facility.

Please ensure that you are matching the correct air spring to the suspension model.

Slider Body Rail Installation

Installation Instructions Model DM400e

Assembly steps to be completed by the trailer manufacturer may include the following:

1. Installation of air tank. Installation may be facilitated by optional tank brackets shown on page m.3, items 4 and 5.
2. Air line plumbing for air springs and height control valve. See illustration on page i.5.
3. Air line plumbing for options:
 - a. For air pin release, see diagram on page i.6.
 - b. For loadblock, see diagram on page i.4.
4. Installation of hubs, drums, bearings, and seals.
5. Installation of wheels and tires.
6. Attachment to trailer:
 - a. Retract lock pins.
 - b. Temporarily remove body rail guides.
 - c. Position slider under trailer and lower trailer onto slider.
 - d. Release lock pins and align with body rail holes.
 - e. Re-install body rail guides and torque nuts to 50 ft. lbs. (70 Nm).
 - f. Attach air lines and electrical connections as needed.

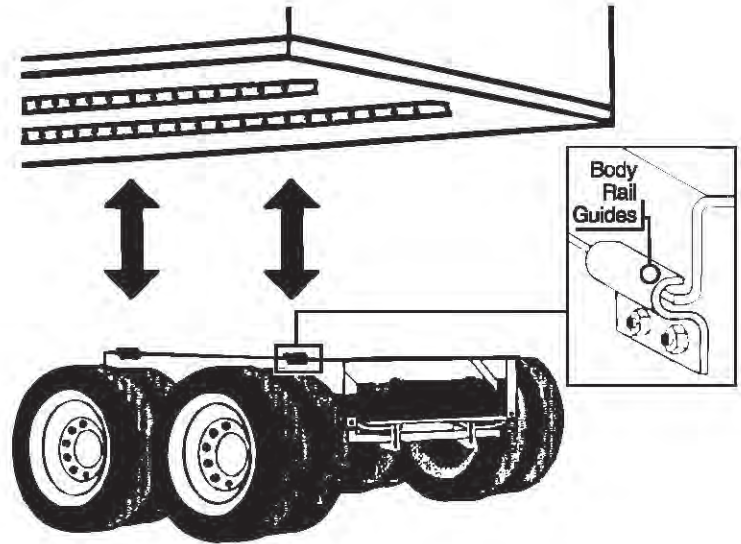

LOADBLOCK INSTALLATION

1. Bolt load block on rear of frame via the lower pairs of 1/2" studs and locknuts.
2. If mudflap brackets are folded in for shipping, remove upper bolts and loosen lower bolts. Then rotate the brackets 90 degrees outwards to align them with the load block brackets.
3. Torque all 1/2" fasteners to 75 ft-lbs (102 Nm).
4. Plumb per instructions below.

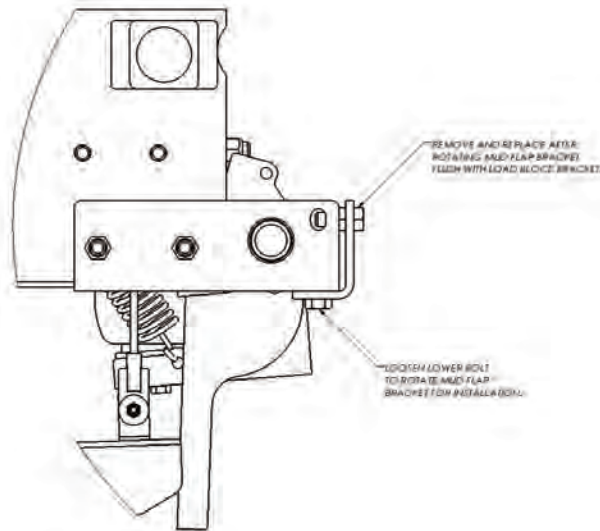
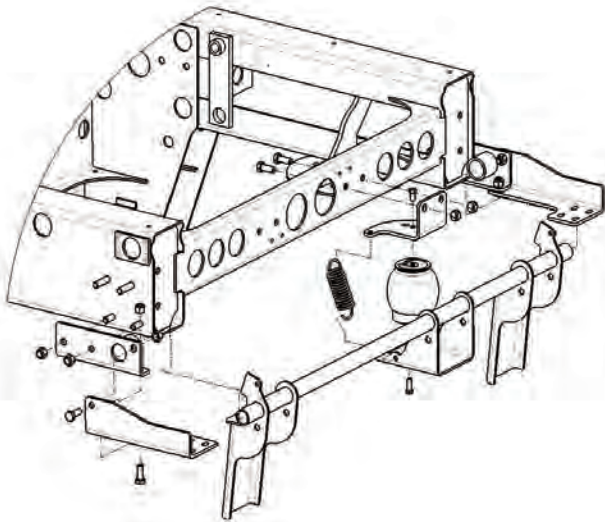

LOADBLOCK PLUMBING

1. Hoses and fittings are not included.
2. 1/4" or 3/8" tubing is to be used.
3. Load block will engage automatically when parking brakes are applied, and will disengage when parking brakes are released.
4. With Load Block engaged (Parking brakes set), there should be a minimum of 3/4 inch gap between the bottom of the paddle and the top of the trailing beam. If an adjustment is necessary, loosen the 7/16 nut attaching the adjusting arm on the height control valve and move the arm to establish the necessary gap. When appropriate spacing is achieved, retighten the 7/16 nut.

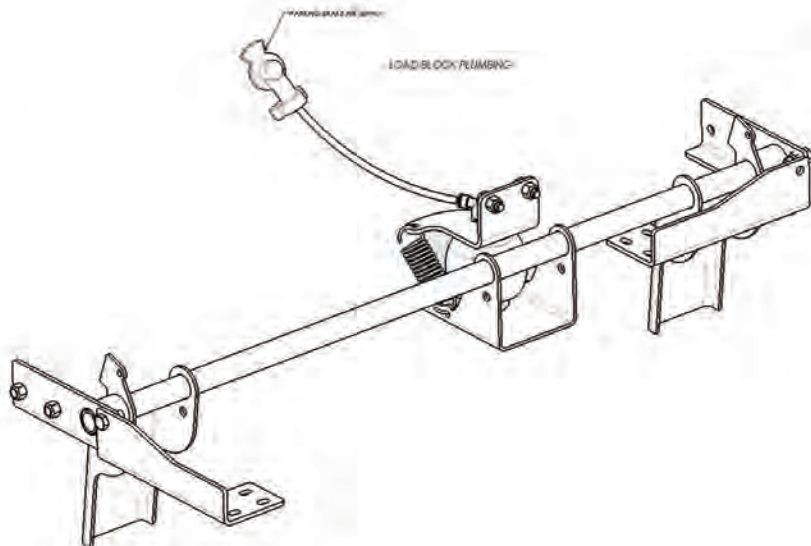

HEIGHT CONTROL VALVE

Height Control Valve Plumbing

1. One height control valve (HCV) is used, regardless of the number of axles. The air springs on each side of the trailer are connected by 3/8" (9.5 mm) minimum diameter tubing (customer supplied)
2. Ensure that the air springs and all valves are plumbed as shown.
3. The pressure protection valve (PPV) and filter are installed between the HCV and the air reservoir.
4. Using customers supplied materials, connect the HCV to all air springs using 3/8" (9.5 mm) diameter tubing as with any pressure system, check for leaks and eliminates leakage, if present.

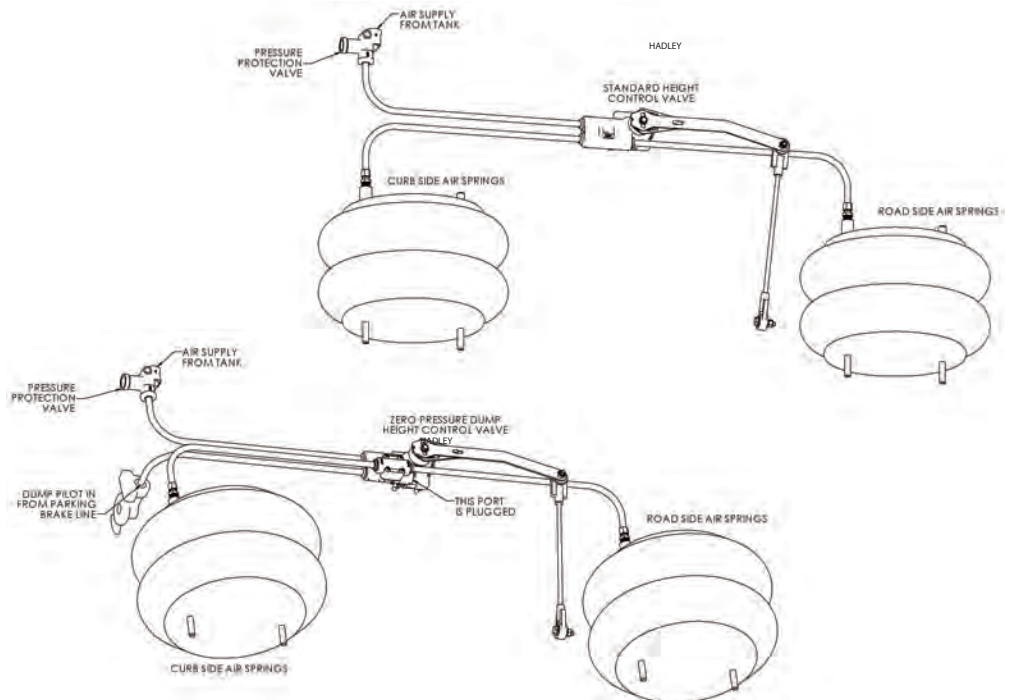
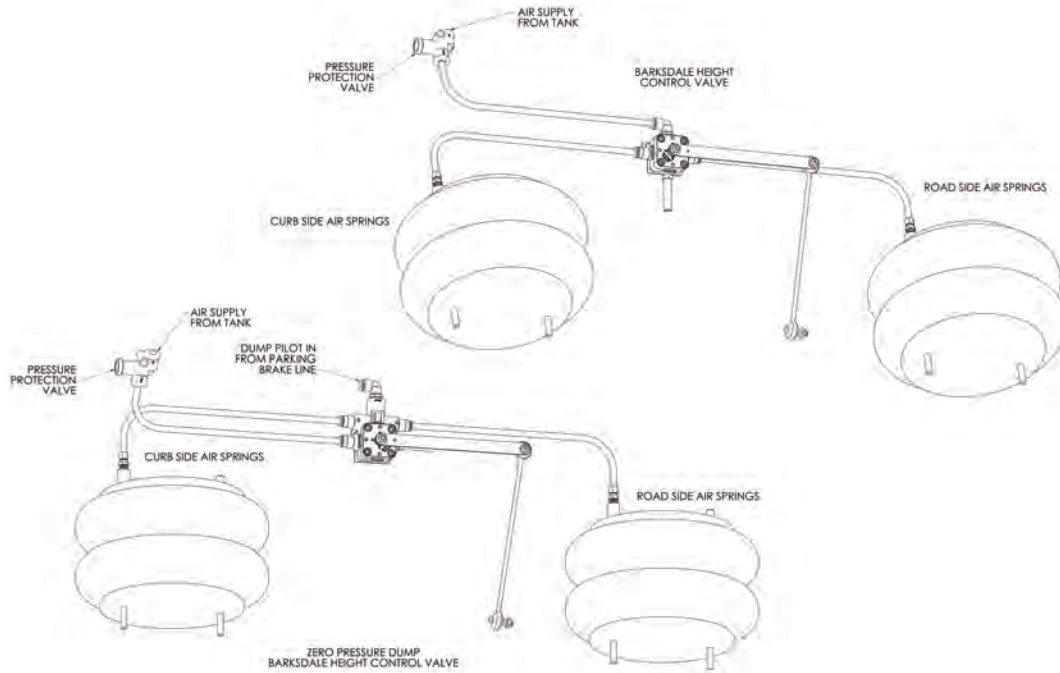

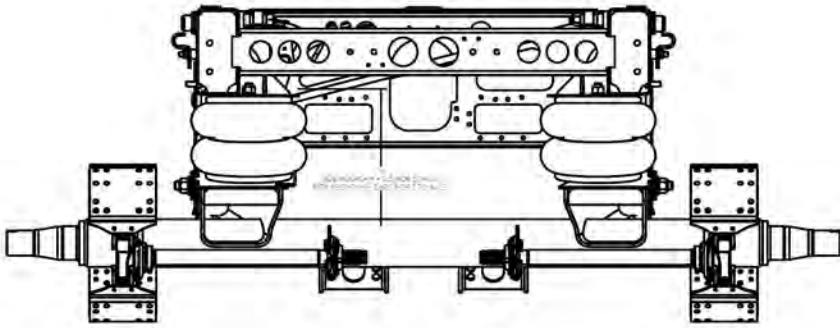

RIDE HEIGHT MEASUREMENT

To measure the ride height of the DM400e suspension, measure from the top of the axle to the top of the air spring support plate. Add 2.5" to this dimension to get the ride height on units equipped with a 5" diameter axle. Add 2.875" on units with a 5.75" axle.

RIDE HEIGHT ADJUSTMENT

HADLEY HCV

Normal Position

To adjust the ride height, the parking brakes on the trailer must be released. Then loosen the bolt in the slot of the height control valve arm. Loosen it just enough so the bolt can slide in the slot. Normal position should look like figure 1.

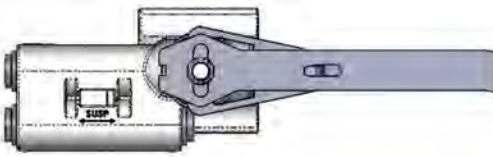

(Figure 1)

How to Raise Ride Height

To raise the suspension height, push up on the pivot area of the arm slightly until air can be heard flowing into the air springs. When the suspension appears to be where it should be, pull down just enough to stop the air flow. The arm is shown up all the way in figure 2.

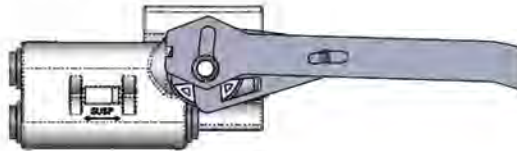

(Figure 2)

How to Lower Ride Height

To lower ride height, pull down on the pivot area of the arm slightly until air can be heard exhausting out of the HCV. When the suspension appears to be where it should be, push up on the arm just enough to stop the air flow. The arm is shown pulled down all the way in figure 3.

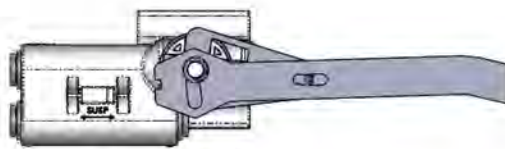

(Figure 3)



Turn CW to raise.

Turn CC to lower.

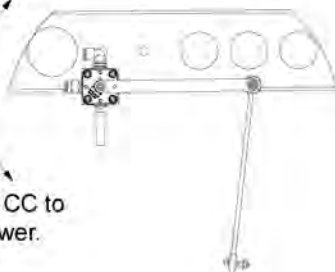

BARKSDALE HCV

Height adjustment on a Barksdale valve is accomplished by loosening the valve bracket mounting bolts that attach to the crossmember and rotating the valve slightly. Rotate clockwise to raise the ride height; rotate counterclockwise to lower it.

Ride Height Measurement & Adjustment

Air Pin Release Plumbing

Installation Instructions Model DM400e

AIR PIN RELEASE

1. Hoses and fittings are not included.
2. 1/4" or 3/8" tubing is to be used.
3. Operation: Upon release of spring brakes (trailer parking brakes), pins will reengage automatically. Inspect slider pins for proper engagement before attempting to move the vehicle.

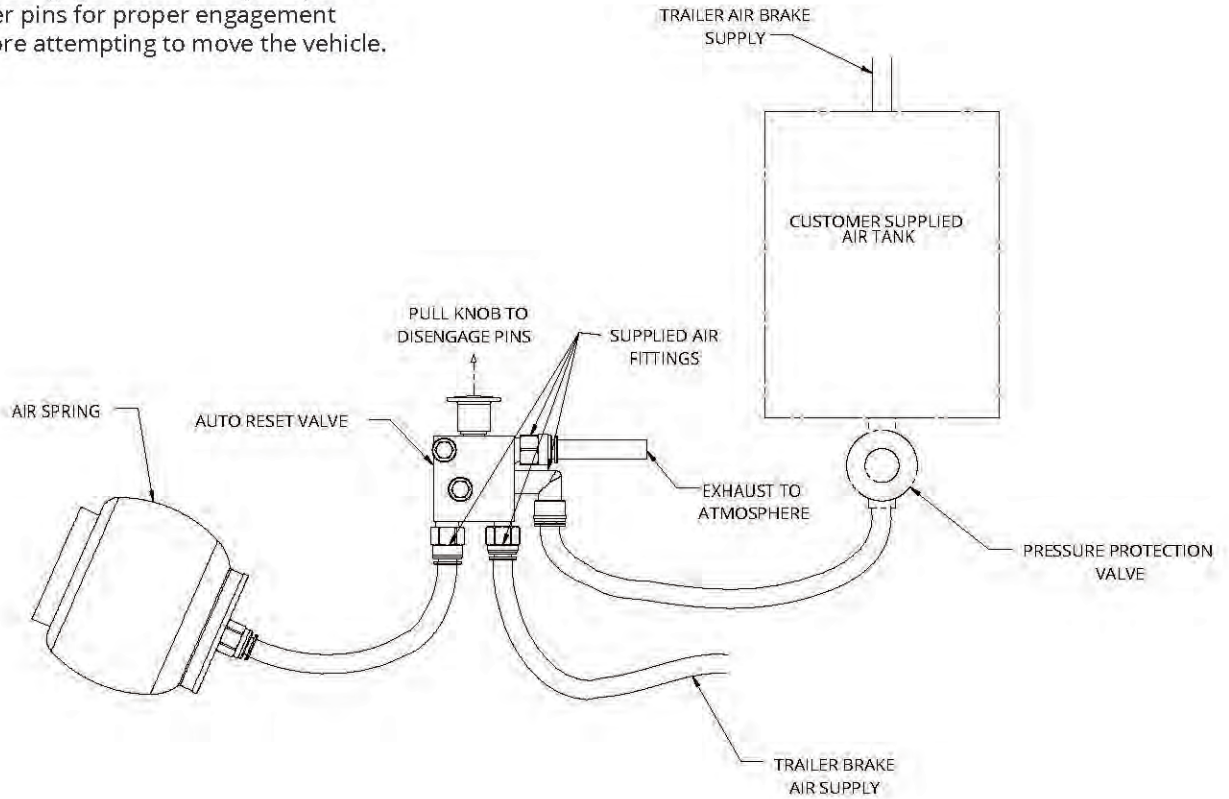

ALIGNMENT

1. Release the brake system and pul the trailer forwards and backwards several times in a straight line to free the suspension from binding and tension.

Note: This procedure must be performed on a smooth level surface.

2. For best results, the use of axle extensions and a bazooka type king pin post, or a suitable optical alignment device are recommended.

3. The suspension assembly leaves the manufacturing facility with the trailing arm pivot bolts snugged to 50 ft-lb (68Nm) of torque.

4. The driver's side (left side) has the Rey-Align assembly installed and approximately centered in the alignment slot.

5. (a) During your alignment check, if alignment is necessary, you must first loosen the adjustable side pivot bolts prior to proceeding with any adjustment. Do NOT loosen the non-adjustable side.

(b) Using your alignment procedures, align target axle to trailer king pin. Target axle can be adjusted using the adjustment bolt in the Rey-Align Tab moving the axle forward or aft as necessary.

(c) Once the target axle has been aligned tighten both pivot nuts until orange indicator dye is forced out of at least three orifices on the TensionRight washers. Alternatively, the nut may be tightened to 475-500 ft-lb (640-680Nm)

(d) Align the second axle with the target axle using the Rey-Align adjustment bolt to adjust. Tighten pivot nuts as was done on the first axle.

(e) Once the pivot bolts have been torqued, verify alignment. If any adjustment is required, pivot bolts must be loosened to adjust using the Rey-Align adjustment bolt. When complete, torque both Rey-Align adjustment bolts to 60 ft-lb (81 NM)

6. After initial 1,000 miles (1,600 km), the alignment should be re-checked and corrected if necessary.

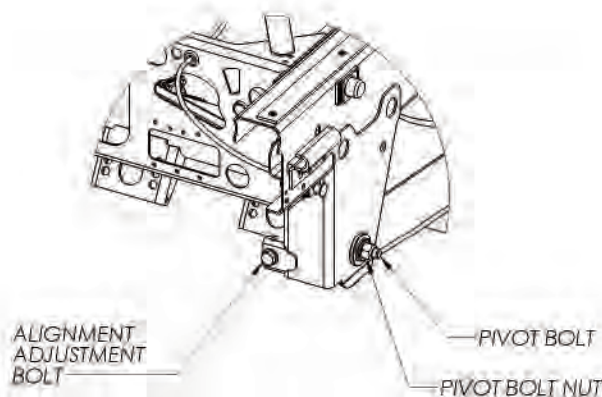
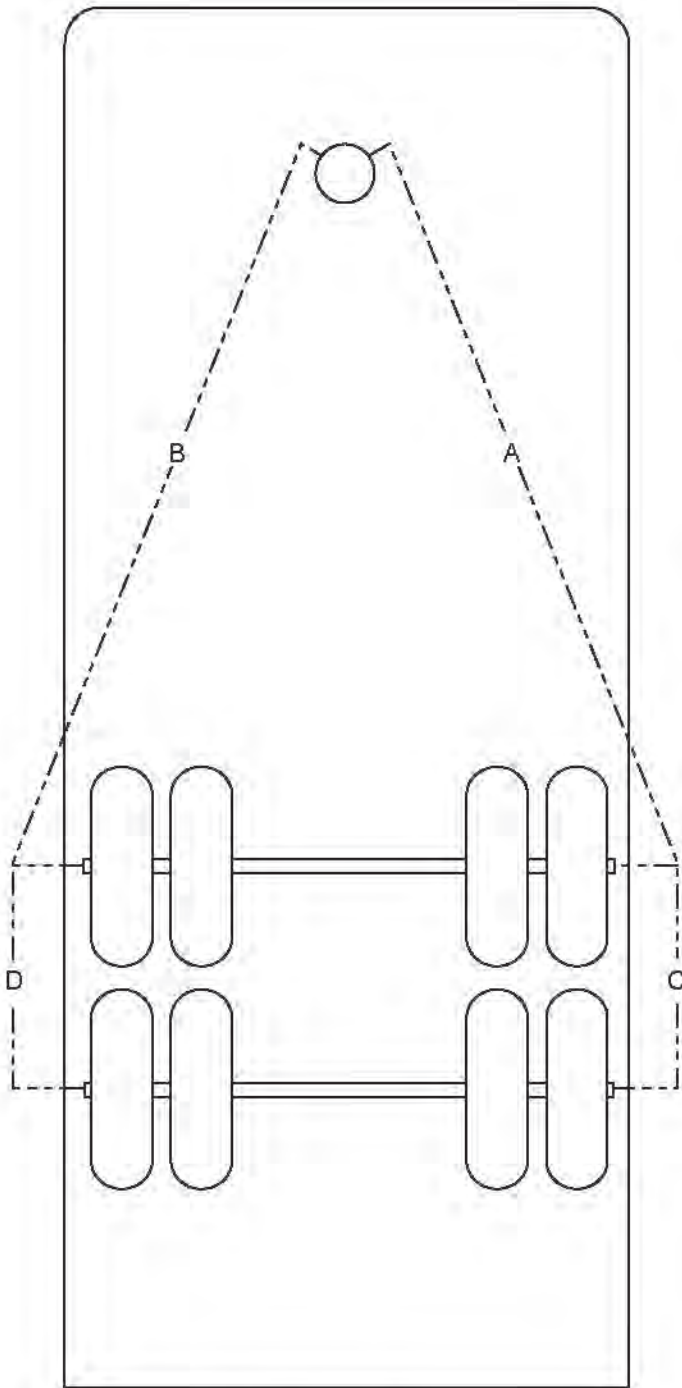

Maintenance Index Page

MAINTENANCE SCHEDULE	○ m.1
Maintenance Schedule	○ m.1
Torque Requirements	○ m.1
Visual Inspection	○ m.1
TRUBLE SHOOTING GUIDE	○ m.2
Fasteners	○ m.2
Bushings	○ m.2
SUSPENSION DRAWING & BILL OF MATERIAL - 713460	○ m.3
SUSPENSION DRAWING & BILL OF MATERIAL - 713459	○ m.4
OPTIONS	○ m.5
Lift Axle Kit	○ m.5
Lift Axle Operation	○ m.6
Galvanized Subframe	○ m.7
Disc Brakes	○ m.4
SERVICE KIT	○ m.8
Trailing Beam Rebush Kit: K710738	○ m.8
MAINTENANCE RECORD	○ m.9

MODEL DM400e MAINTENANCE INSTRUCTIONS

The Reyco Model DM400e suspension, by design requires minimum maintenance. Suspensions require periodic checks to assure continued trouble-free performance.

DM400e RECOMMENDED MAINTENANCE SCHEDULES

1. Pre-service inspection
2. First service inspection, after 1,000 - 3,000 miles, (1,600 - 4,800 km)
3. PM inspections, concurrent with DOT "C" inspections - Annually
4. During replacement of any service parts
5. Upon discovery of any loose components

TORQUE REQUIREMENTS

Verify with each scheduled inspection

1. Tighten pivot bolt-475-500 ft lb (640-680 Nm)
2. Tighten Rey-Align-60 ft lb (81 Nm)
3. Tighten shock absorber bolts-175-200 ft lb (237-275 Nm)
4. Tighten upper 1/2" air spring nuts-25-30 ft lb (34-41Nm)
5. Tighten upper 3/4" spring retainer nuts-25-30 ft lb (55-60Nm)
6. Tighten lower 3/8" spring retainer nuts-15-20 ft lb (20-28 Nm)
7. Tighten 1/4" air valve linkage nut-5 ft lb (7Nm)

VISUAL INSPECTION

1. Loose or missing fasteners
2. Cracks in hangers or axle connection

If any of the above defects are noted, have vehicle checked by a qualified technician. Torque values are specified with clean, lightly oiled fasteners, and should only be verified with a calibrated torque wrench. Failure to follow these instructions could void the warranty and could result in subsequent injury.

ft lb = Foot Pounds; Nm = Newton Meters

FASTENERS

Loose fasteners need immediate attention. Check components for wear and be sure holes are not worn or egg shaped. When replacing, be sure threads are clean, lightly oiled and not deformed. Consult the maintenance section for the correct torque specification. To insure an accurate torque reading, the torque tool used for checking torque, must provide a correct measurement.

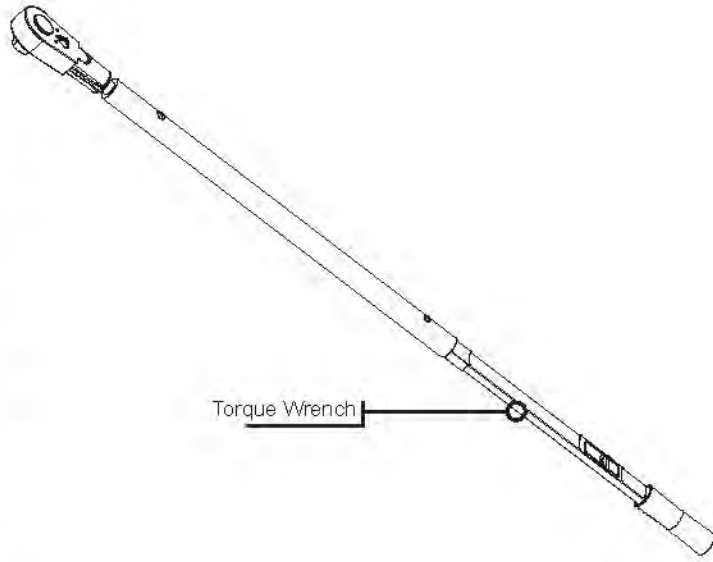

Torque Wrench

BUSHINGS

Inspect rubber bushings for large splits, tears and major wear. Rubber is attacked by sun, oils and greases. Replace any bushings which have noted damage.

Use P80 Rubber Lubricant or equivalent water or soap and water.

Note: Keep bushing cavities at top and bottom when installing.

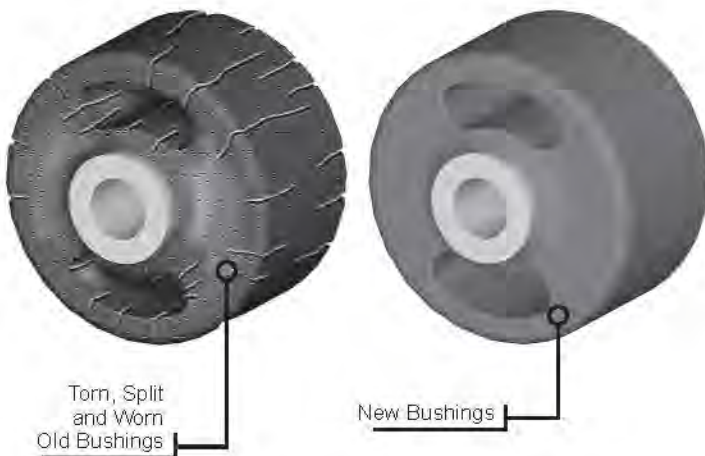

Torn, Split and Worn Old Bushings

New Bushings

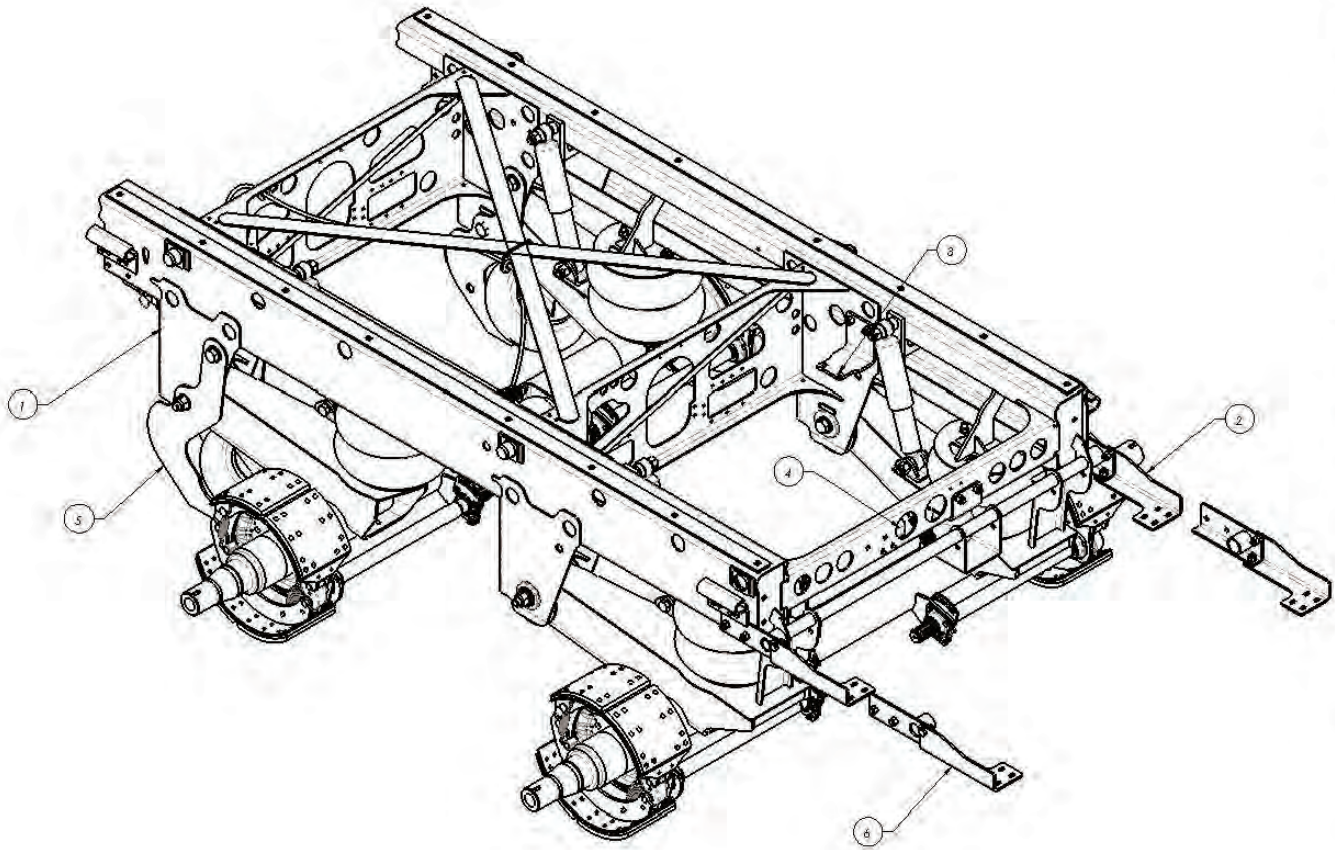

Drawing #713460/714045

Item	Part No.	Drawing No.	Description	Qty.
1	Various	713459	Suspension Assembly	1
2	713321-01	713321	Load Block Assembly, Main	1
3	711922-01	711922	Assembly-Air Tank Bracket-Rear	1
4	711970-11	711970	Height Control Valve-Hadley 1500	1
5	K712880	712880	DM400 Bolt on Lift Axle	1
6	713499-01	713499	Mud Flap Bracket Kit	1

Drawing #713459/714144

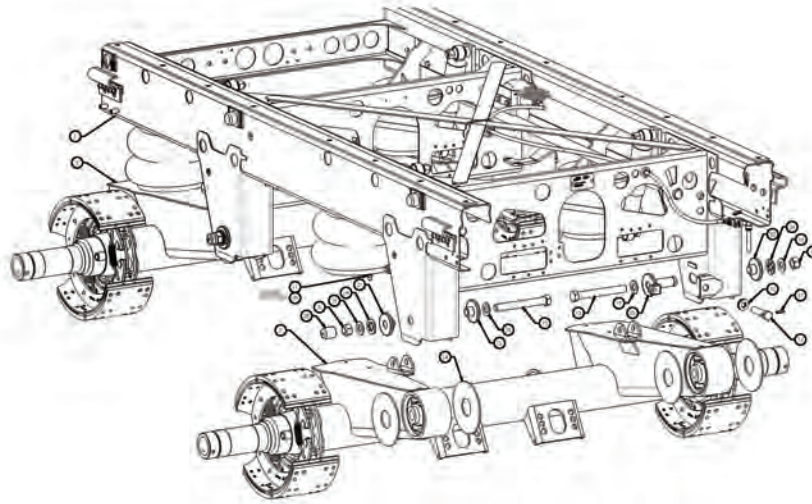

ITEM	PART NO.	DWG NO	DESCRIPTION	QTY.
1	713458-11	713458	SUBFRAME ASSEMBLY	1
2	713650-01	712188	FRONT BEAM AXLE ASSEMBLY LDA	1
3	713652-01	713652	REAR BEAM AXLE ASSEMBLY LDA	1
4	21496-01	62158#4	HCS (3/4-16UNF-2A X 3.5 LG) GR 5	4
5	12889-01	62158#1	HCS (3/4-16UNF-2A X 4 LG) GR 5	4
6	08211-01	93280	HEX NUT (3/4-16UNF-2B) CLASS 5	4
7	12920-01	93280	HEX NUT (1/2-13UNC-2B) CLASS 5	4
8	14345-01	93281	LOCK NUT (7/8-14UNF-2B) CLASS C	4
9	14344-01	93281	LOCK NUT (3/4-16UNF-2B) CLASS C	8
10	713580-01	79167	AIR SPRING ASSEMBLY	4
11	20029-01	93280	HEX NUT (3/8-16UNC-2B) CLASS 5	8
12	20852-01	701785	WASHER (3/4 ID)	4
13	23286-02	62158#4	HCS (7/8-14UNF-2A X 7.5 LG) GR 8	4
14	23427-01	97202	BEAM SPACER	8
15	T-7292	701785	WASHER (7/8 ID)	8
16	24398-01	98480	REY-ALIGN ADJUSTMENT SHAFT	2
17	24453-01	98486	COILED SPRING PIN	2
18	700098-01	700098	SHOCK ABSORBER	4
19	T-1705	62159	0.5 ID LOCK WASHER	4
20	T1859	62159	0.375 ID LOCK WASHER	8
21	T-3164	62159	0.75 ID LOCK WASHER	4
22	707924-01	707924	REY-ALIGN WASHER, CAST	6
23	707865-01	707865	REY-ALIGN ADJUSTER, CAST	2
24	713429-01	713429	A 490 7/8 TENSIONRIGHT WASHER	4
25	714535-01	714535	PIVOT NUT CAP	2

	Part Number	Item One	Item Two	Item Three	Body Rail	Spindle	Mounting Height	Width	Weight (LBS)
		Subframe Assembly	Axle/Beam Assembly - Front	Axle/Beam Assembly - Rear					
5" DIAMETER AXLE	713459-01	713458-11	711896-01	711365-01	HUTCH	TAPERED	15.5	48 3/8	1,372
	713459-02	713458-15	711896-01	711365-01	TTMA	TAPERED	15.5	48 3/8	1,371
	713459-03	713458-19	711896-01	711365-01	BINKLEY	TAPERED	15.5	48	1,370
	713459-51	713458-11	711896-51	711365-51	HUTCH	STRAIGHT	15 1/2	48 3/8	1,382
	713459-52	713458-15	711896-51	711365-51	TTMA	STRAIGHT	15.5	48 3/8	1,381
	713459-53	713458-19	711896-51	711365-51	BINKLEY	STRAIGHT	15.5	48	1,380
5" DIAMETER AXLE WABCO DISK BRAKES	714771-51	713458-11	712503-51	712502-51	HUTCH	STRAIGHT	15.5	48 3/8	1,746
	714771-52	713458-15	712503-51	712502-51	TTMA	STRAIGHT	15.5	48 3/8	1,745
	714771-53	713458-19	712503-51	712502-51	BINKLEY	STRAIGHT	15.5	48	1,744
5.75" DIAMETER AXLE	714144-01	713458-11	713652-01	713650-01	HUTCH	TAPERED	15.5	48 3/8	1,310
	714144-02	713458-15	713652-01	713650-01	TTMA	TAPERED	15.5	48 3/8	1,309
	714144-03	713458-19	713652-01	713650-01	BINKLEY	TAPERED	15.5	48	1,308
	714144-51	713458-11	713652-51	713650-51	HUTCH	STRAIGHT	15.5	48 3/8	1,320
	714144-52	713458-15	713652-51	713650-51	TTMA	STRAIGHT	15.5	48 3/8	1,319
	714144-53	713458-19	713652-51	713650-51	BINKLEY	STRAIGHT	15 1/2	48	1,318

Lift Axle Kit - K712880

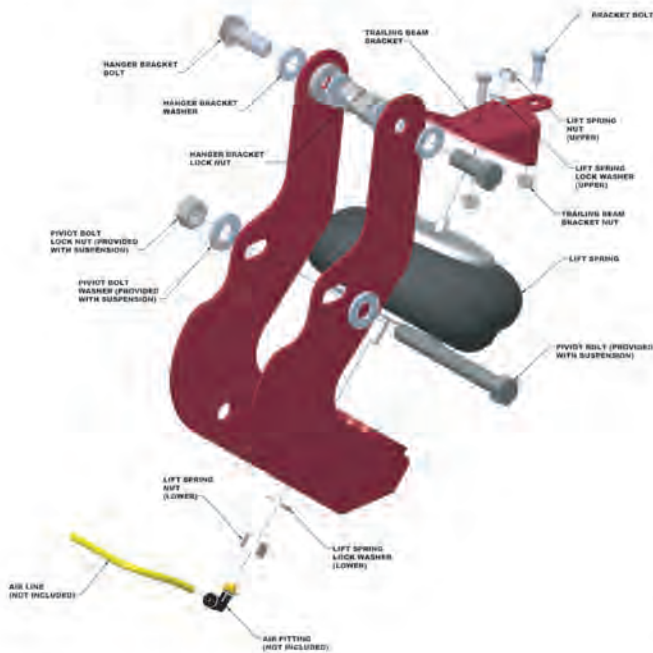

Lift Axle Kit Installation

1. If hangers are undrilled, drill 15/16" diameter holes on each side of hangers according to the drawing provided.



2. Drop 7/16" bolts through holes in trailing beam accessing from the opening in the rear of the trailing beam. Attach trailing beam bracket to the bottom of the beam using the 7/16" locking flange nuts. Torque to 60 Ft-lbs (81 Nm).
3. Attach lift spring to trailing beam bracket with lock washer and nut. Torque to 20-30 Ft-lbs (27-41 Nm).
4. Support the trailer, then remove the trailing beam pivot bolt and place hanger bracket in position. Replace the pivot bolt to hold the hanger bracket in position.

Bill of Materials

Part #	Description	QTY
712523-01	Hanger Bracket Assembly (left hand)	1
712523-02	Hanger Bracket Assembly (right hand)	1
712874-01	Trailing Beam Bracket Assembly - left hand	1
712874-02	Trailing Beam Bracket Assembly - right hand	1
701784-01	Lift Spring	2
700144-28	Hanger Bracket Bolt	4
T-7292	Hanger Bracket Washer and Pivot Bolt Washer	8
14345-01	Hanger Bracket Lock Nut	4
700144-29	Trailing Beam Bolt	4
700525-10	Trailing Beam Bracket Nut	4
12920-01	Lift Spring Nut (upper)	2
T-1705	Lift Spring Lock Washer (upper)	2
08211-01	Lift Spring Nut (lower)	2
T-3164	Lift Spring Lock Washer (lower)	2

NOTE: Pivot bolt, pivot bolt washer and pivot bolt lock nut are not included in kit. Please use the original hardware from the suspension pivot connection.

5. Align lift spring lower stud with plate on hanger bracket. Rotate hanger bracket about pivot bolt, compressing the lift bag and lining up the holes for upper hanger bracket bolts. Place upper hanger bracket bolts in holes with washers and lock nuts.
6. Fasten lift spring to hanger bracket spring plate using the lock washer and nut provided. Torque to 40-50 Ft-lbs (55-68 Nm).
7. Torque upper hanger bracket bolts to 400 - 425 Ft-lbs (540-575 Nm).
8. Check axle alignment and correct if necessary. Torque pivot bolts to 400-425 Ft-lbs (540-575 Nm).
9. Install air fittings and plumbing. (Not included)

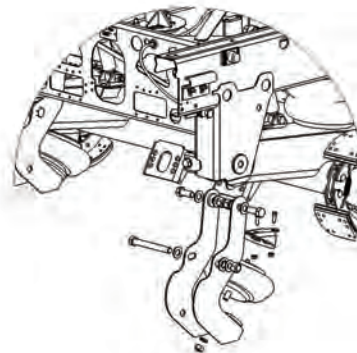

Maintenance Instructions Model DM400e

DM400e FRONT LIFT AXLE CONTROLLED BY MERITOR WABCO ABS

This system is designed to lift the front axle when the trailer is empty or lightly loaded, by controlling the front axle lift air bags and the front axle load (main) air bags. The height control valve controls the rear axle load air bags.

This system is designed to lift or lower the front axle automatically without driver intervention under predetermined conditions.

AUTO LIFT

When power is supplied to the trailer and the parking brakes are released, the system will check the pressure in the load air bags. If the pressure is below 27 psi (gross axle weight of 6,500 lbs), the front axle will lift.

AUTO LOWER

The front axle will automatically lower and stay down when any of the following conditions occur:

1. When electrical power is removed from the trailer, either by turning the key off in the tractor or by disconnecting the power cable from the trailer.
2. When the trailer parking brakes are applied.
3. When the rear axle load bag registers at 83 psi or more. This corresponds to a gross axle weight of 17,000 lbs or more on the rear axle.

Conditions 1 and 2 above are to: a) prevent the front axle from being raised while parked, b) prevents the rear axle from being overloaded while fork lifts are loading the trailer, and c) prevent the tires from being stolen.

Condition 3 above prevents the trailer from being over-weight on one axle while on the road.

PROCESS AFTER TRAVELING WITH FRONT AXLE RAISED

When the trailer has been traveling with the front axle lifted and is then parked, the front axle lowers and the height control valve system begins to function normally and will fill the front axle load bags while reducing the rear axle load bags to equalize the pressure between all load bags on both axles.

When the trailer is ready to move again and power is supplied to the trailer and the parking brakes released, the system will check the pressure in the load bags. If the pressure is 27 psi or more, the front axle will remain lowered. If the pressure is less than 27 psi, the front axle will lift.

If at some point weight is added to the trailer that caused the pressure in the rear load bags to exceed 83 psi, the system will lower the front axle and will keep it lowered until such time that the pressure drops below 27 psi.

Galvanized Subframe

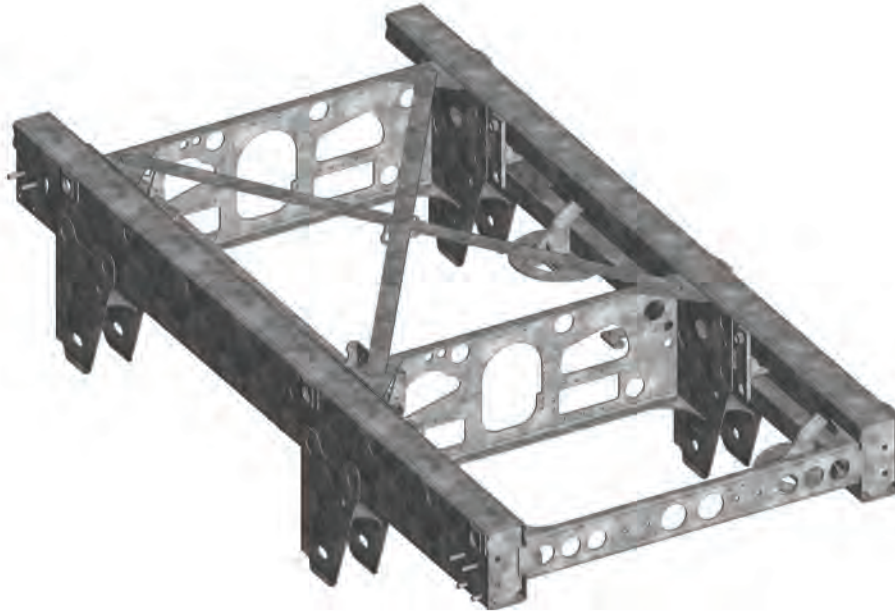

Options - Galvanized Subframe

	Part Number	Item One	Item Two	Item Three	Body Rail	Spindle	Mounting Height	Width	Weight (LBS)
		Subframe Assembly	Axle/Beam Assembly - Front	Axle/Beam Assembly - Rear					
5" DIAMETER AXLE	713459-01	713458-11	711896-01	711365-01	HUTCH	TAPERED	15.5	48 3/8	1,372
	713459-02	713458-15	711896-01	711365-01	TTMA	TAPERED	15.5	48 3/8	1,371
	713459-03	713458-19	711896-01	711365-01	BINKLEY	TAPERED	15.5	48	1,370
	713459-51	713458-11	711896-51	711365-51	HUTCH	STRAIGHT	15 1/2	48 3/8	1,382
	713459-52	713458-15	711896-51	711365-51	TTMA	STRAIGHT	15.5	48 3/8	1,381
	713459-53	713458-19	711896-51	711365-51	BINKLEY	STRAIGHT	15.5	48	1,380
5" DIAMETER AXLE WABCO DISK BRAKES	714771-51	713458-11	712503-51	712502-51	HUTCH	STRAIGHT	15.5	48 3/8	1,746
	714771-52	713458-15	712503-51	712502-51	TTMA	STRAIGHT	15.5	48 3/8	1,745
	714771-53	713458-19	712503-51	712502-51	BINKLEY	STRAIGHT	15.5	48	1,744
5.75" DIAMETER AXLE	714144-01	713458-11	713652-01	713650-01	HUTCH	TAPERED	15.5	48 3/8	1,310
	714144-02	713458-15	713652-01	713650-01	TTMA	TAPERED	15.5	48 3/8	1,309
	714144-03	713458-19	713652-01	713650-01	BINKLEY	TAPERED	15.5	48	1,308
	714144-51	713458-11	713652-51	713650-51	HUTCH	STRAIGHT	15.5	48 3/8	1,320
	714144-52	713458-15	713652-51	713650-51	TTMA	STRAIGHT	15.5	48 3/8	1,319
	714144-53	713458-19	713652-51	713650-51	BINKLEY	STRAIGHT	15 1/2	48	1,318

Trailing Beam Rebush Kit

Service Kit

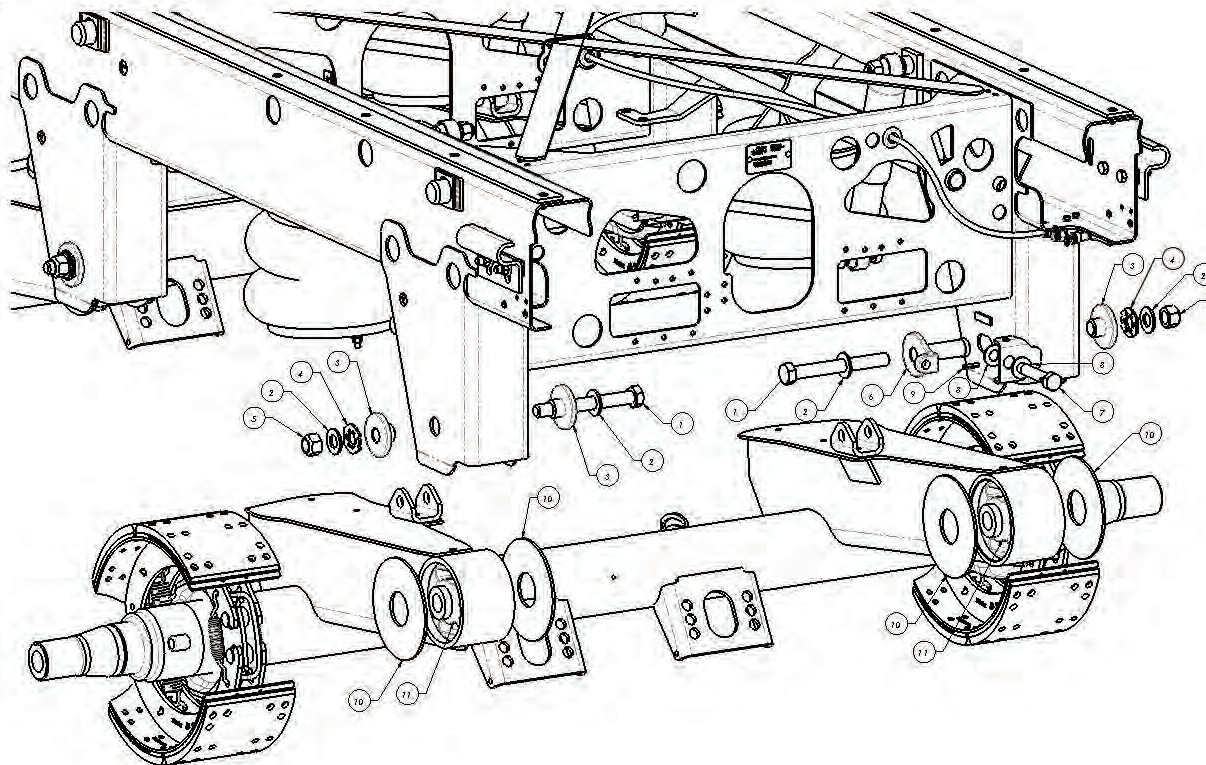

K710738 - one (1) axle

Item	Component	Description	Quantity
1	23286-02	BOLT, HEX 7/8-14 UNF 7.50 GR.8	2
2	T7292	FLAT WASHER 7/8 X 1.75, .157 J IT	4
3	707924-01	REY ALIGN WASHER-CAST	3
4	713429-01	TENSIONRIGHT WASHER 7/8	2
5	14345-01	L'NUT, HEX 7/8-14 UNF GR.C	2
6	707865-01	REY ALIGN ADJUSTER-CAST	1
7	24398-01	BOLT, HEX 3/4-10 UNC 3.5 W/HOLE	1
8	20852-01	FLAT WASHER 3/4 X 1.48, .120	2
9	24453-01	COILED SPRING PIN	1
10	23427-01	BEAM SPACER 7 X 2 3/8, 3/16	4
11	25770-01	BUSHING	2

Maintenance Record

Maintenance Record

Name of Owner		Address of Owner	
Date of Purchase	Name and Address of Dealer		
Model of Vehicle	Vehicle Identification Number		
Suspension Model Number:	Suspension Serial Number:		
Inspection and Maintenance Item	Date	Mileage	Service Performed

Page Intentionally Left Blank

Reyco[®]
Granning[®]
S U S P E N S I O N S

Reyco Granning Suspensions
1205 Industrial Park Drive
Mount Vernon, MO 65712
Phone: 417-466-2178
Fax: 417-466-3964
ISO Certified: 9001:2015
www.reycogranning.com